

# The Bike Storage Company

## Battersea Tenant Cycle Stores

Tel: 0800 246 1723

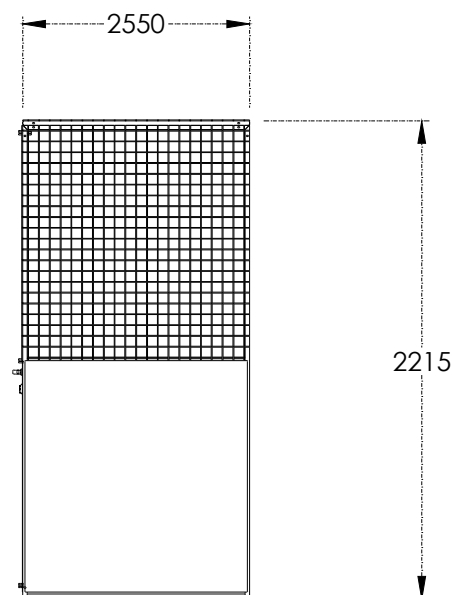
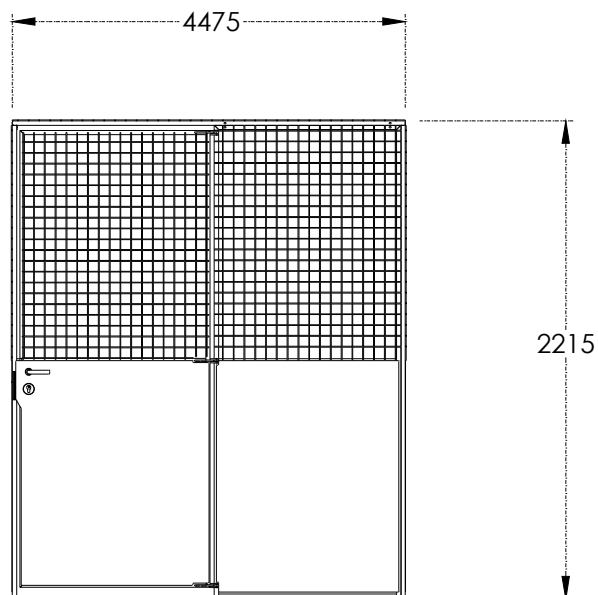
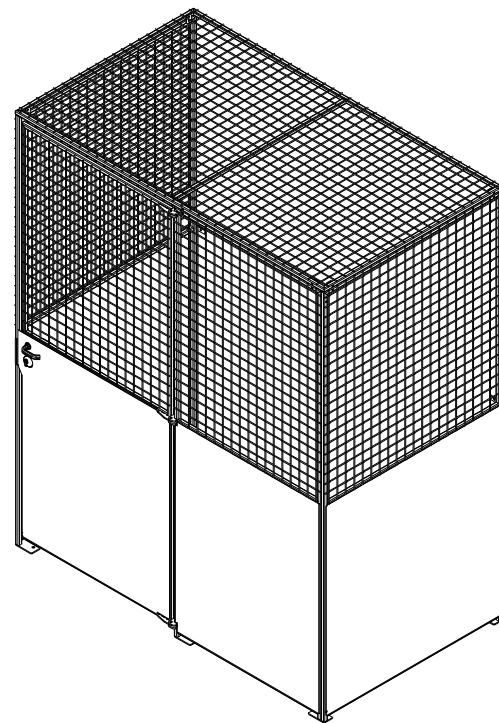
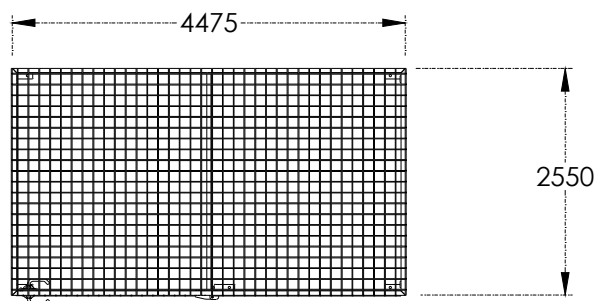

- Standard dimensions: 1820mm x 2215mm x 1050mm
- 20 SHS framework and 50x50 mesh galvanised or PPC to various RAL options
- Modular design, can be extended or amended to suit almost any size
- Available in a range of lock options (superlock latch deadlock as standard)
- Secure ground anchor

**Legend:**

ALL DIMENSIONS ARE IN MM UNLESS OTHERWISE STATED. IF IN DOUBT PLEASE ASK.  
 THIS DRAWING IS CONFIDENTIAL AND IS THE PROPERTY OF THE BIKE STORAGE COMPANY. IT MUST NOT BE COPIED OR DISCLOSED TO A THIRD PARTY WITHOUT PERMISSION.  
 THE BIKE STORAGE COMPANY, MARINA STUDIOS, HARBOUR YARD, LONDON, SW10 0XD

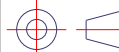

THE  
**BIKE STORAGE**  
 COMPANY  
 0800 246 1723

Client: The Bike Storage Company  
 Status: Approval  
 Date Drawn: 30/08/2023  
 Draftsperson: W Martin  
 Third Angle Projection

Project: Battersea Tenant Cycle Store Drawing  
 Title: TBSC\_BatterseaTenantStore\_DR\_00-1  
 Scale: 1:35 @ ISO A3  
 DWG No: 1.0

Revision: 00